

# Boiler Structure

Static Simulation of boiler structure in power plant using MSC Apex and MSC Nastran

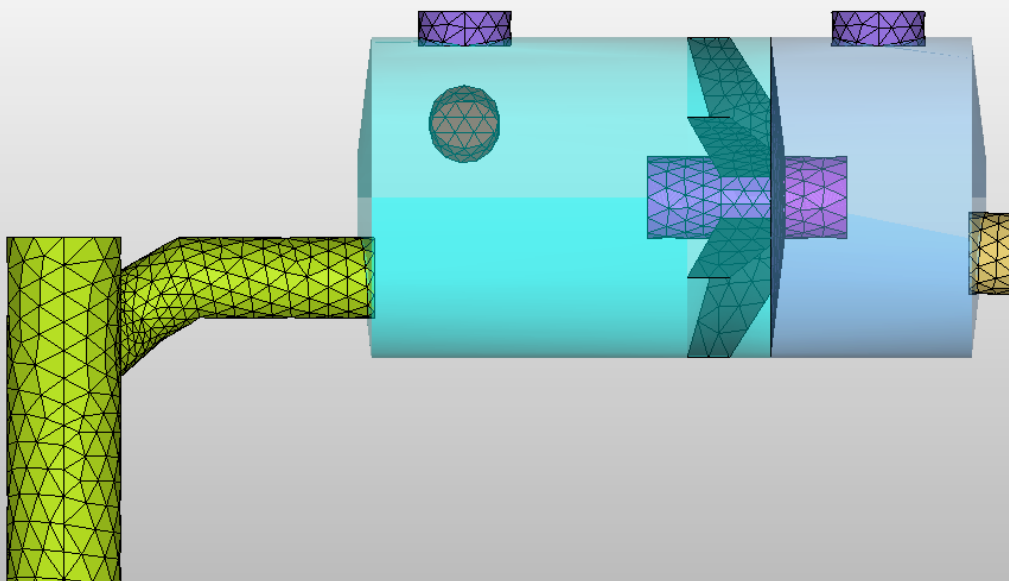

## Introduction

Power plant sites consists of numerous built up structures, each of which must be designed for positive margins of safety. Finite Element Analysis (FEA) is a common numerical method used for determining and improving the strength and dynamic performance of such structures.

With an increasing need to find optimal power plant structural designs, the most efficient FEA workflows are critical. This case study discusses methods to expedite the FEA process, namely: rapid construction of Finite Element meshes from geometry and leveraging FEA technology to quickly connect hundreds of structural members.

## Challenge

Most industrial structures consists of hundreds of structural members, many of which have the common trait of being thin-walled. This boiler structure, part of a large power plant, is an example that is characterized by thin-walled members. Finite Element Analysis (FEA) is a common method used for strength analysis, but the large size of this structure presents a number of challenges that can delay FEA. The first challenge involves constructing the finite element model, and traditionally requires hours of work. The second challenge is adjoining numerous structural members together, but the process should be both rapid and without error. The use of MSC Apex for mesh construction and the use of MSC Nastran for analysis is demonstrated.

### Design with MSC Apex

The process of creating the Finite Element Mesh (FEM) model is accelerated by MSC Apex.

The boiler structure in Figure 1 is over 54 meters tall and consists of numerous beam members. In MSC Apex, the Constant Thickness method of midsurface extraction is chosen to create middle surfaces. Considering the large scale of the whole model, the Constant Thickness method can create midsurfaces in seconds. The H-shape beams, on the other hand, don't have a constant thickness. So the "Incremental Midsurface" method was used, which uses a Face Pair approach to produce midsurfaces, as shown in Figure 2. The Face Pairs are effectively guides for subsequent midsurface extraction. Then the midsurfaces of the different parts are connected by the Auto-Extend functionality, which extends and stitches the surfaces automatically. The remaining free edges are connected by manual vertex-edge drag. Modifying and repairing of this structure can be carried out easily.

### Simulation with MSC Nastran

For simplicity and given the grand scale of the boiler structure, only the top 3 levels of the structures are considered.

After the midsurface geometry is created, the boiler structure model is meshed in MSC Apex, see Figure 3. In addition, a Young's modulus, Poisson's ratio and density of material are set and then applied to all of the structure parts. Thicknesses and offset properties are automatically generated using the original solid geometry.

The model is then passed on to a separate pre/post process for further FEM configuration and ultimately analyzed using MSC Nastran, see Figure 4. For this model, there are three kinds of boundary conditions. Firstly, the vertical H-beams at the bottom are regarded as fully fixed supports. Secondly, the main load for boiler structure is the weight of facilities on every floor. So the weight of boiler, generator, steam turbine and other maintenance facilities are referenced and exerted to each corresponding floor. The average load on each floor is 49 tons. The last steps involves connecting the various structural members including the floorboards and beams. Glue Contact technology is used to connect the structural members, and the Contact Table serves as a matrix indicating which member is attached to other members.

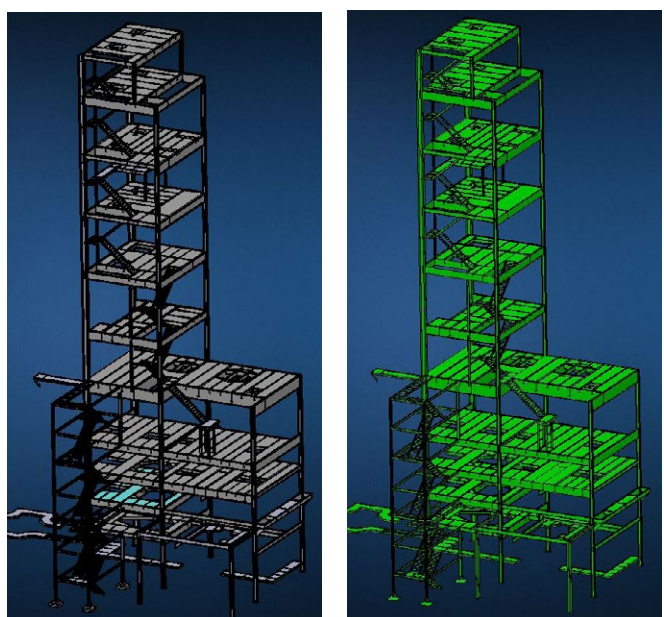

Figure 1. Original model and Middle surface of modified model

## Results/benefits

Figure 5 shows the deformation of the loaded boiler structure. In these plots, the original geometry is colored in green, and the deformed geometry is colored in red. When the deformation is presented in true scale, there is almost no visible differences between the original and deformed geometry. In order to show the deformation clearly, the deformation is scaled to 5% of the largest dimension.

Then displacement fringe is plotted on the deformed geometry, shown in Figure 6. According to the color distribution, the largest displacement appears on the top floor. The plot in Figure 7 is related to the result of von Mises stress tensor.

Most parts of structure are of color blue, which means that the stress are within range of safety. It is also observed that some surfaces marked by red, produce relatively larger stress than others. If the stress values are higher than limit, as determined by this result plot, locations that need to be re-designed can be quickly identified.

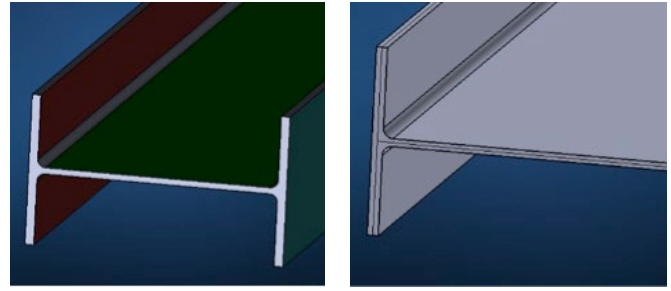

Figure 2. Midsurface of H-beam, top: face pairs identified by MSC Apex

Key highlights:
Product: MSC Apex, MSC Nastran
Industry: Energy
Benefits:
MSC Apex accelerates the creation of midsurface geometry and FEM model
MSC Nastran Glue Technology is leveraged to perform strength analysis on highly an interconnected structure

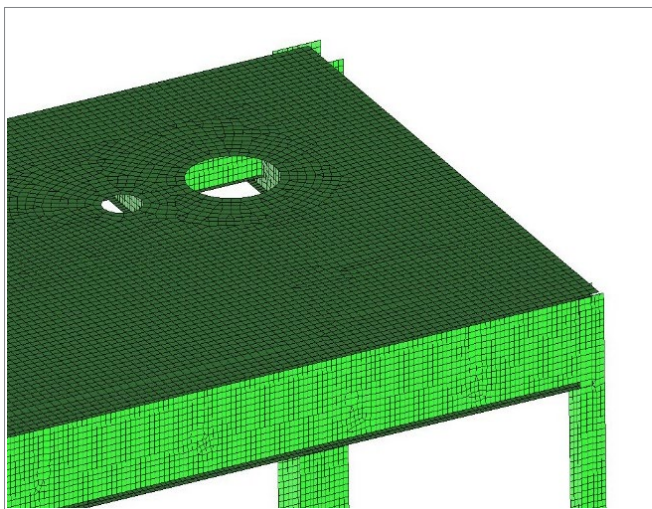

Figure 3. Meshing

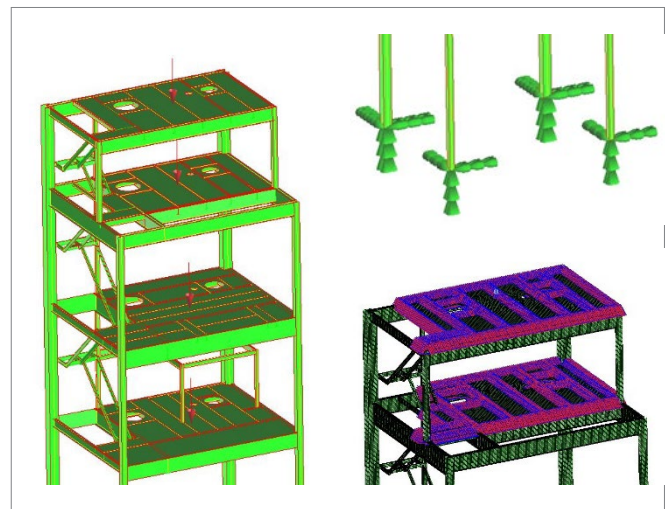

Figure 4. Constraints

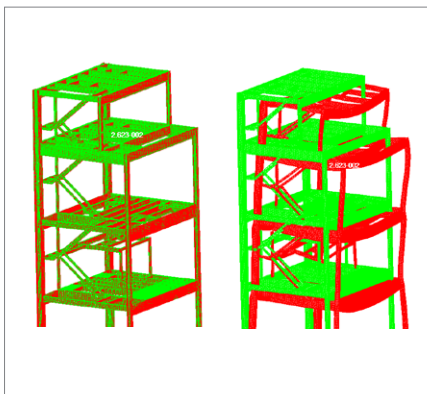

Figure 5. Deformation of true scale and defamation of 5% enlarged scale

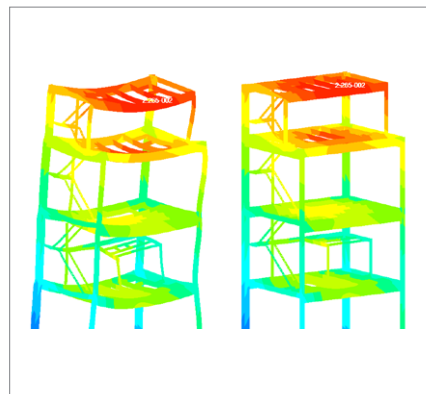

Figure 6. Displacement fringe

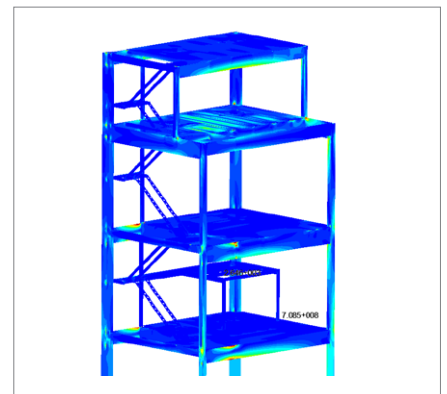

Figure 7. Von Mises stress tensor



Hexagon is a global leader in sensor, software and autonomous solutions. We are putting data to work to boost efficiency, productivity, and quality across industrial, manufacturing, infrastructure, safety, and mobility applications.

Our technologies are shaping urban and production ecosystems to become increasingly connected and autonomous – ensuring a scalable, sustainable future.

MSC Software, part of Hexagon's Manufacturing Intelligence division, is one of the ten original software companies and a global leader in helping product manufacturers to advance their engineering methods with simulation software and services. Learn more at [mscsoftware.com](https://www.mscsoftware.com). Hexagon's Manufacturing Intelligence division provides solutions that utilise data from design and engineering, production and metrology to make manufacturing smarter.

Learn more about Hexagon (Nasdaq Stockholm: HEXA B) at [hexagon.com](https://www.hexagon.com) and follow us [@HexagonAB](https://twitter.com/HexagonAB).